

Features

ICU HiTech bed is equipped with the most advanced technology for the patient intensive care.

Its three rectangular lifting and lateralization columns are safety and durability warranty. Multiple options are available to satisfy the patient care necessities, which optimize the work of the caregivers.

- Encourage the patient welfare due to:

The bed lateralization allows patient better oxygenation to avoid complications and facilitates his dairy care.

The rails have an anti-fall protection system that locks the bed lateralization whilst the rails are lowered.

Foot section positioning system in different angles by a hinge.

Double regression system, it reduces the pressure in the thorax area, minimizing the pressure ulcers risk (PU's) (165 mm ± 10 mm).

X-ray ready because of its radio transparent backrest.

- Easy handling:

Membrane control integrated in the rails that facilitate the bed positioning for the patient and for the caregiver. The rails come assembled with two inside membrane controls and two external for the caregiver.

The bed has a battery in case the main power fails or the bed is unplugged. It allows doing more than 300 complete movements.

High precision weighing system, installed in the rails that allows the tracking and monitoring of the patient condition.

Other of its characteristics are:

- IP66 linear actuators.
- 250 Kg. maximum safety load.
- Minimum height 420 mm.
- HPL bed base.
- 200 mm. legs section extensible length.

- Optional customizable vinyls in colour and logo.

HiTech bed has a wide range of accessories and complements that enable to comply with all the needs of a hospital room and intensive care units.



HiTech Bed



Technical information

Total length with headboard and footboard (A) *	2200 mm. ± 10 mm.
Total width with rails (B)	970 / 1010 mm. ± 10 mm.
Minimum/maximum bed base height (without mattress) (C y C') **	420 / 820 mm. ± 10 mm.
Extremities section extensible length	200 mm.
Crane passing clearance height (D) **	170 mm.
Bed base section length (E, F, G y H)	790 / 170 / 320 / 620 mm.
Bed base section width (I)	830 mm.
Wheels diameter	150 mm.
Backrest tilting angle (J)	70° ± 5°
Extremities and feet tilting angle (K y L)	45° / 18° ± 2°
Bed base sections double regression	165 mm. ± 10 mm.
Trend / Reverse Trend position angles	18° / 18° ± 2°
Laterall tilt	20° ± 2°
Maximum patient weight (MPW)	205 kg.
Safety weight load (SWL)	250 kg.
Bed unladen weight	150 kg.

* The length of the bed in the headboard anchored option is 2240 mm. ± 10 mm.

** This heights can vary ± 40 mm. according to the bed configuration (wheels model, etc)

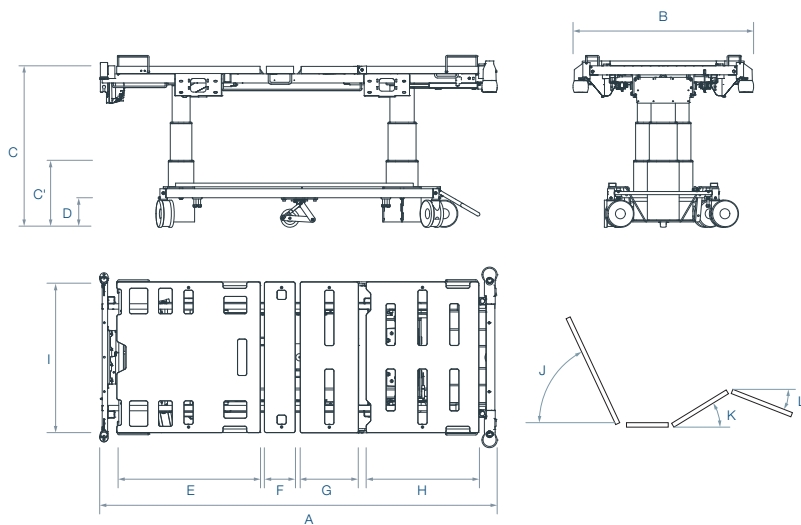

Electrical information

Lifting system	By 3 columns
Backrest lifting system	By linear motor
Extremities lifting system	By linear motor
Voltage and frequency	230 V / 50 - 60 Hz
Electric shock protection / liquid penetration	Class I / Type B / IP66
Maximum consumption	Max. 3 15A (maximum 400 W)
Motor intermittent operation	10% 2 min. - 18 min.

Standard

Controls	Protection	Transport	Wellness	Others	Accessories
Patient control	Full length rails	Ø150mm double covered wheels	Lifting feet rastomat	Battery	IV Pole
Nurse control	Removable headboard	Centralised braking	Under bed lighting	Trapeze bar	Table under footboard
Railing membranes					

Optional

Controls	Protection	Transport	Wellness	Others	Accessories
Lifting pedal	Anchored headboard	5th wheel	Lifting feet spring	Brake alarm	X-ray cassette tray
		Brake pedal	Weighing	Tilttable table	Tank holder