

Newcare Bariatric Bed

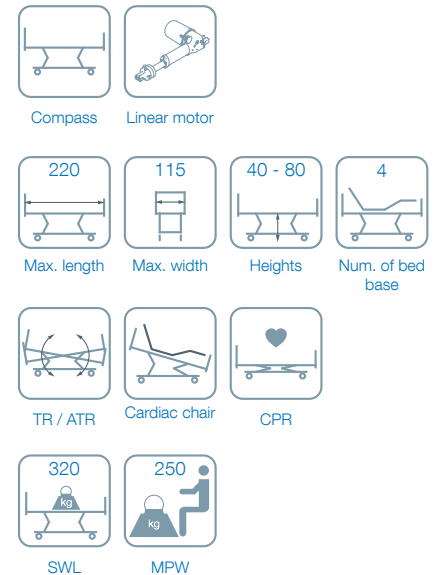

Features

NewCare Bariatric bed is a complete electric and articulated bed with a compass with linear actuators lifting system (IP66 protection level).

This patient bed version seeks to resolve a variety of care problems, treatments and safety issues for patients up to 250 kilos.

The lifting chart is made of high resistance steel with epoxy coating to ensure durability and strength.

Furthermore, NewCare Bariatric bed has a wide range of accessories and complements that enable to comply with all the needs of a hospital room and intensive care units.

Some of its main characteristics are:

- IP66 linear actuators.
- 320 kg safety weight load (SWL)
- HPL hand removable bed base divided in 4 sections.
- Extensible bed base, up to 30 cm.
- 4 protection cylinders in each corner.
- Protection against the growth and spread of bacteria.
- Double regression system, it reduces the pressure in the pelvic area, minimizing the pressure ulcers risk (PU's) (165 mm). Polypropylene made side rails with grip zone and folding system by gas spring.
- Centralized brake system by pedals located in the footboard and headboard area (2 + 2).
- Light weight bed, makes easy the bed handling.



NewCare Bariatric Bed



Technical information

Total length with headboard and footboard (A)	2200 mm. ± 10 mm.
Total width with rails (B)	1090 / 1150 mm. ± 10 mm.
Bed base height (low position) (C)	400 mm. ± 10 mm.
Bed base height (high position) (D)	800 mm. ± 10 mm.
Crane passing clearance height	170 mm.
Extremities section extensible length	300 mm.
Bed base width (E)	980 mm.
Bed base section length (F / G / H / I)	790 / 170 / 320 / 620 mm.
Backrest tilting angle (J)	70° ± 5°
Extremities tilting angle (K)	45° ± 2°
Feet tilting angle (L)	18° ± 2°
Trendelenburg / Reverse Trend position angles	13° / 15° ± 2°
Maximum patient weight (MPW)	250 kg.
Bed unladen weight (SWL)	320 kg.

* The length of the bed in the headboard anchored option is 2240 mm. ± 10 mm.

** This heights can vary ± 40 mm. according to the bed configuration (wheels model, etc)

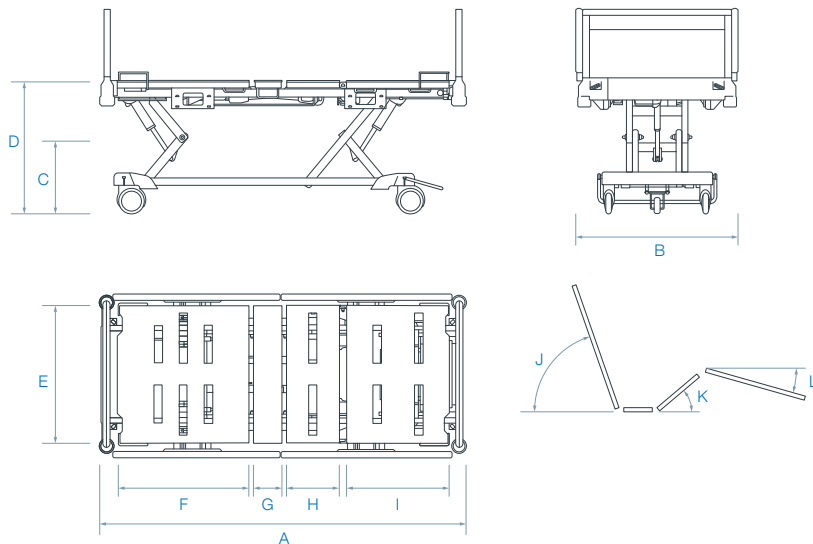

Electrical information

Lifting system	By linear motors
Backrest lifting system	By linear motor
Extremities lifting system	By linear motor
Voltage and frequency	230 V / 50 - 60 Hz
Electric shock protection / liquid penetration	Class II / Type B / IP66
Maximum consumption	Max. 3 15A (maximum 400 W)
Motor intermittent operation	10% 2 min. - 18 min.

Standard

Controls	Protection	Transport	Wellness	Others	Accessories
Patient control with blockages	Full length rails	Ø150mm double covered wheels	Lifting feet rastomat		IV Pole
	HPL removable headboard	Brake pedal			Trapeze bar

Optional

Controls	Protection	Transport	Wellness	Others	Accessories
Patient control	Side rails	5 th wheel	Gas spring foot section	Brake alarm	X-ray cassette tray
Blockages control				Battery	Tiltable table
Railing membranes				Under bed lighting	Tank holder
Lifting pedal					
Nurse control					